

ECTC Test Protocol
Proposed ASTM Test Method
(including ASTM revisions as of March 2004)

Designation: ASTM D XXXX

STANDARD TEST METHOD FOR DETERMINATION of UNVEGETATED ROLLED EROSION CONTROL PRODUCT (RECP) ABILITY TO PROTECT SAND FROM HYDRAULICALLY-INDUCED SHEAR STRESSES UNDER BENCH-SCALE CONDITIONS

1.0 Scope

1.1 This index test method establishes the guidelines, requirements and procedures for evaluating the ability of unvegetated Rolled Erosion Control Products (RECPs) to protect soil (sand) from hydraulically induced shear stress.

1.2 This index test method utilizes bench-scale testing procedures and is not indicative of unvegetated RECP performance in conditions typically found in the field.

1.3 This index test is not intended to replace full-scale simulation or field testing in acquisition of performance values that are required in the design of erosion control measures utilizing unvegetated RECPs.

1.4 The values stated in SI units are to be regarded as standard. The inch-pound values given in parentheses are provided for information purposes only.

1.5 This standard does not purport to address all of the safety concerns, if any, associated with its use. It is the responsibility of the user of this standard to establish appropriate safety and health practices and determine the applicability of regulatory limitations prior to use.

1.6 This standard offers an organized collection of information or a series of options and does not recommend a specific course of action. This document cannot replace education or experience and should be used in conjunction with professional judgment. Not all aspects of this standard may be applicable in all circumstances.

2.0 Referenced Documents

2.1 ASTM Standards

D 653 Terminology Relating to Soil, Rock, and Contained Fluids

D 698 Test method for laboratory compaction characteristics of soil using standard effort

D 3740 Practice for Minimum Requirements for Agencies Engaged in the Testing and/or Inspection of Soil and Rock as Used in Engineering Design and Construction⁵

D 4354 Practice for Sampling of Geosynthetics for Testing

D 6460 Test method for Determination of Erosion Control Blanket (ECB) Performance in Protecting Earthen Channels from Stormwater-Induced Erosion

3.0 Terminology

3.1 For definitions of terms used in this practice, see Terminology D 653.

4.0 Summary of Test Method

4.1 Soil cores consisting of containers with bare soil and/or RECP-protected soil are immersed in water and subjected to shear stresses caused by the rotation of an impeller with three blades. At a minimum, testing of containers with bare soil should be performed when a new or renewed soil stockpile is used.

4.2 The amount of soil that erodes at each of three shear stress levels is measured.

5.0 Significance and Use

ECTC Test Protocol

Proposed ASTM Test Method
(including ASTM revisions as of March 2004)

5.1 This index test method indicates an unvegetated RECP's ability to reduce soil erosion caused by shear stresses induced by moving water under bench-scale conditions.

5.2 This test method is bench-scale and therefore, appropriate as an index test for general soil/product composite behavior under hydraulic shear conditions, and for product quality assurance/conformance testing. **The results of this test may not be indicative of an unvegetated RECP's actual field performance.**

6.0 Apparatus

6.1 The shear stress test apparatus includes a shear tank, false floor with test wells, transition cover plate, and motor-driven impeller. (See Figure 1.)

6.1.1 Shear Tank - A cylindrical tank of sufficient diameter and depth to develop the desired shear levels. (See Fig. 1 for an example)

6.1.2 False Floor - A false floor shall be positioned in the tank with at least three test wells cut into the false floor to hold soil cores. When soil cores are placed in the wells, the soil surfaces must be flush with the false floor surface. (See Fig. 1.)

6.1.3 Motor-driven Impeller Assembly - The impeller motor shall be capable of driving the impeller assembly at sufficient revolutions per minute (RPMs) to develop the necessary shear stresses. The blades of the three-blade impeller must be sufficiently long enough to extend to within 25 mm (1 in) of the side of the tank. The impeller is mounted in the tank so that the lower edge of the blades is $115 \text{ mm} \pm 1 \text{ cm}$ ($4.5 \pm 0.4 \text{ in}$) above the false floor of the tank in which the test cores are seated during testing. (See Fig. 1.) The apparatus should be capable of producing shear stresses in 24 Pascal (pa) (0.5 pounds/square foot (psf)) increments below, near, and above expected target shear stress levels.

Note: The shear stress apparatus shown in Figure 1 has been found sufficient for achieving shear stresses between 24 and 72 pa (0.5 and 1.5 psf) on degradable RECPs.

6.1.4 Soil Cores - Consist of water-tight containers nominally $200 \pm 10 \text{ mm}$ ($8 \pm 0.4 \text{ in}$) inside diameter plastic pipe section cylinders with height of $100 \pm 10 \text{ mm}$ ($4 \pm 0.4 \text{ in}$) holding soil and test specimens.

7.0 Sampling

7.1 The laboratory sample should be at least 2 m^2 (6.5 ft^2).

7.2 If possible, cut a single circular coupon having a diameter 50 mm (2 in) less than the tank diameter from the roll sample. This should be of sufficient size to cover the entire false floor and three soil cores when seated in the test wells.

8.0 Procedure

8.1 Calibration of Test Apparatus

8.1.1 Calibration of the apparatus determines the impeller motor setting and associated revolutions per minute that exerts the desired tractive force on the test surfaces. See Annex for calibration guidance.

8.1.2 At a minimum, calibration should be conducted for each RECP tested and each time a new soil stockpile is used.

8.2 Test Set-up

ECTC Test Protocol

Proposed ASTM Test Method
(including ASTM revisions as of March 2004)

8.2.1 Prepare nine soil cores for each temporary degradable RECP to be tested and nine bare-soil control cores. Weigh each core completely submerged in water to determine its Submerged Mass (SM_s) and record to ± 0.01 grams (g) before filling with soil.

8.2.1.1 Fill and compact the cores flush with soil. Unless otherwise requested, compact soil to 90% of Standard Proctor density, at a soil moisture within $\pm 3\%$ of optimum moisture content per ASTM D-698. Submerge compacted cores in water for 24 hours to complete saturation. Each test should be conducted on freshly prepared cores. See Annex 2.0 for sand details.

NOTE: The standard sand used in this test procedure has been found to be successful for general product comparison purposes. However, site-specific and/or user-defined soils may be used based on user needs. If non-standard soils are used, agreement should be established between the testing laboratory and the user of the test.

8.2.1.2 If testing is to be done with vegetated soil cores, unless otherwise agreed upon between the testing laboratory and user, vegetated soil cores used in testing shall be prepared in accordance with Annex 3.0.

8.2.1.3 Weigh each prepared soil core in its submerged state to determine its Initial Submerged Mass (SM_i) and record to ± 0.01 grams (g).

Note: Typically a balance is supported above the water level of the tank with a device to reach down and hold the soil core below the water level during weighing. A similar weighing is done at the end of the test to facilitate the determination of soil loss during the test.

8.2.1.4 Calculate the Submerged Mass of the Soil (SM_s) in each core by subtracting the submerged weight of the empty core from the submerged weight of the soil-filled core and record to ± 0.01 g.

8.2.1.5 Calculate the Core linear Density (C_d) by dividing the SM_s by the unit length of the core and record in g/mm).

8.3 Test Operation and Data Collection

8.3.1 Place three prepared and weighed soil cores in the test wells of the false floor. When soil cores are placed in the wells, the soil surfaces must be flush with the false floor surface.

8.3.2 For RECP testing, place the RECP over the entire false floor and hold it in place on the soil core surfaces by covering it with a 1.0mm (0.038 in) cover plate. The cover plate shall have arc or trapezoidal-shaped openings approximately equal to the diameter of the test cores in width (the radial direction) and approximately 75mm (3.0 in) larger in length (both upstream and downstream circumferentially) than the diameter of the test cores to completely expose the protected soil surfaces of the cores. (See Figure 1.).

8.3.3 Fill the tank with water so that the impeller blades are covered. A line should designate the initial height of water. Fill in such a way that the water does not disturb the surface of the RECP/soil.

8.3.4 Activate the shear stress apparatus to rotate the impeller assembly at the RPM level determined from the calibration procedures necessary to achieve the target shear stress. Unless otherwise agreed to between the testing laboratory and user of the test, the RECP / bare soil control cores shall be subjected to a minimum of three flow tests at three different shear stress levels to encompass the shear stress at which 13 mm (0.5 in) of soil loss will occur in the test cores.

Note: Commonly in channel erosion testing, 13 mm (0.5 in) of soil loss is considered a point of maximum allowable soil loss. Therefore, it is recommended that the first test run be at a shear stress level sufficient to invoke approximately 13 mm (0.5 in) of soil loss from the soil core. This may be accomplished by selecting a shear stress at or near the RECP's advertised and/or published permissible shear stress. After determining soil loss achieved

ECTC Test Protocol
Proposed ASTM Test Method
(including ASTM revisions as of March 2004)

during the first test, a minimum of two additional tests shall be performed, one at a higher level of shear stress and one at lower level of shear stress at a minimum of 24 pa (0.5 psf) above/below the initial target shear stress.

8.3.5 Allow test to run for 30 minutes.

8.3.6 Remove each soil core from its test well, being careful to retain all the remaining soil, and determine its Final Submerged Mass (SM_f).

8.3.7 Repeat 30-minute test on new RECP-protected cores at higher/lower shear stress levels.

8.3.8 Conduct a similar set of tests for the bare soil control cores at a minimum, when a new or renewed soil stockpile is used.

ECTC Test Protocol
 Proposed ASTM Test Method
(including ASTM revisions as of March 2004)

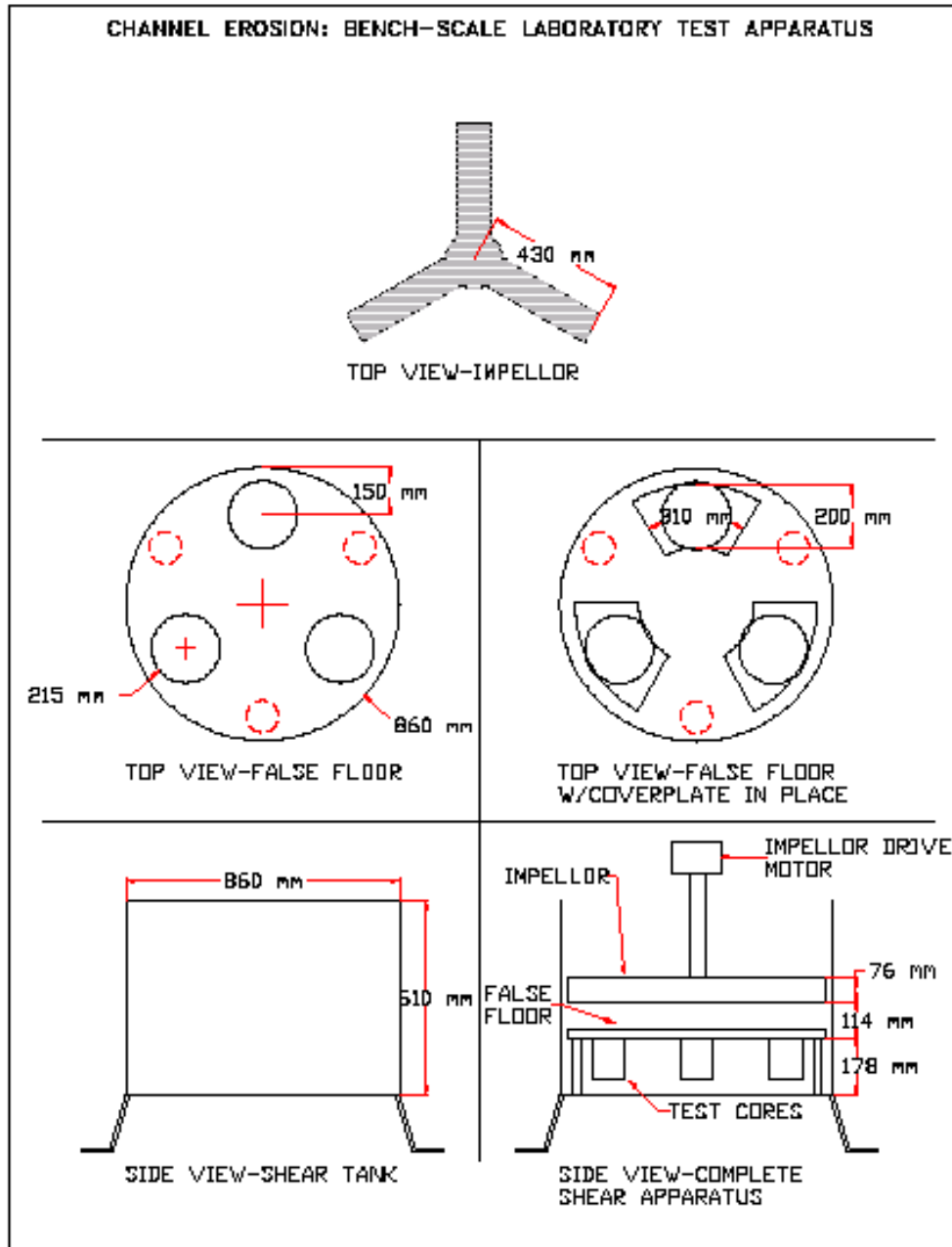

FIG. 1. CHANNEL EROSION: EXAMPLE OF A BENCH-SCALE LABORATORY TEST APPARATUS

9.0 Calculations

9.1 Record the Final Submerged Mass (SM_f) of soil for each of the three cores for the RECP and bare soil control sets at each shear stress level.

9.2 Calculate the average depth of Soil Loss (mm) for each Core (SL_c) as follows: $SL_c = (SM_i - SM_f) / Cd$

Where SM_i = Initial submerged mass of core (g)

ECTC Test Protocol

Proposed ASTM Test Method
(including ASTM revisions as of March 2004)

SM_f = Final submerged mass of core (g)
 Cd = Core linear density (g / mm)

9.3 Calculate the Mean Soil Loss (SL_{avg}) in mm for each set of three cores by averaging the SL_c values of all three cores.

9.4 Plot SL_{avg} vs. shear stress (in Pa and (lbs/sf)) for each 30minute test. All data points should be shown and used for curve fitting. On the graph, note the point at which the soil loss curve crosses 13 mm (0.5 in) of soil loss.

9.5 Calculate the Shear Stress Ratio (SSR) for the test RECP as follows: $SSR = tp_{(0.5 \text{ in } SL_{avg})} / tc_{(0.5 \text{ in } SL_{avg})}$

Where: $tp_{(0.5 \text{ in } SL_{avg})}$ = Shear stress on RECP-protected cores at 0.5 inch average soil loss
 $tc_{(0.5 \text{ in } SL_{avg})}$ = Shear Stress on bare soil control cores at 0.5 inch average soil loss

10.0 Report

10.1 The report shall at a minimum include the following:

10.1.1 General information, including test facility location, date, time, and dimensions of test apparatus.

10.1.2 Calibration data and analysis for each RECP tested

10.1.3 Test set-up activities, including 1) test conditions (shear stress levels); 2) soil type and conditions, and; 3) RECP product type and description

10.1.4 The sand gradation and standard proctor moisture-density relationship shall be reported. If other soils are used, the soils information shall include: soil type/texture (i.e. topsoil, sandy loam, silt loam, clay); standard proctor moisture-density relationship; gradation (including hydrometer test for the P200 fraction); organic matter content; plasticity indices; and pH.

10.1.5 Raw data, initial and final submerged masses, core densities and depth of soil loss for each core.

10.1.6 Graph displaying SL_{avg} in mm (in) vs. shear stress in Pa (lbs/sf) for all three RECP and bare soil tests. Denote on graph the shear stress level at which 13 mm (0.5 in) of soil loss would be expected.

10.1.7 The calculated Shear Stress Ratio (SSR) for each RECP.

11.0 Precision, Bias and Reproducibility:

11.1 Precision: The precision of the test is being determined.

11.2 Bias: The bias of the test, if any, is being determined.

11.3 Reproducibility: The reproducibility of the test is being determined.

12.0 Keywords: Erosion control, rolled erosion control product, RECP, shear stress, shear stress ratio.

ECTC Test Protocol
Proposed ASTM Test Method
(including ASTM revisions as of March 2004)

ANNEX
Mandatory Information

A1.0 Calibration of Flow/Shear Simulator

A1.1 Due to inherent differences in surface roughness characteristics of various unvegetated RECPs, each RECP tested in the shear stress apparatus will have its own shear stress vs. impeller speed (RPM) relationship. For this reason, it is necessary to calibrate the shear tank for each RECP and soil tested within it. Procedural guidelines for calibration of the shear tank are provided below.

A1.2 Mount the top of a solid aluminum “stress” column onto the bottom of a 203 mm (7.95 in) diameter plastic calibration disk having a thickness of 3 mm (0.125 in). The aluminum column should have dimensions no less than 25 mm (1 in) square by 150 mm (6 in) in height.

A1.3 Attach a 200 mm (8 in) diameter specimen of the RECP to the top (exposed) surface of the calibration disk. The use of glues, small wire braces, etc. are acceptable to attach the RECP to the calibration disk as long as the attachment mechanism does not contribute hydraulic shear resistance during calibration testing.

A1.4 Mount a similar aluminum reaction column onto the bottom of the shear tank in a position 25 mm (1 in) offset on the “downstream” side of a position directly beneath the center of a sample well in the false floor.

A1.5 Insert the RECP covered plastic calibration disk equipped with the aluminum column into one of the sample wells so that the column extends downward towards the floor of the tank, a short distance away from the reaction column. Assure that the calibration disk moves freely around the sample well and is not wedged into a locked position. If the disk is too tight, remove and sand around the edges to achieve a loose fit within the sample well. Cover the other sample wells with a similar plastic disk with the same RECP attached.

A1.6 Mount a water-resistant load cell with calibrated stress readout between the stress and reaction columns. Be careful to seal the electrical connections to and from the load cell with an appropriate water-resistant gel.

A1.7 Fill the shear tank with water and activate the impeller assembly. Slowly increase the RPMs of the impeller and record the RPM reading at each 4.8 pa (0.1 psf) increment of increasing shear stress. Allow no less than 2 minutes at each RPM reading to establish an accurate and consistent reading from the load cell .

A1.8 The index limiting shear stress shall be calculated as follows:

$$\tau_i = \frac{\text{Load cell reading- Kg (lbs)}}{A} \quad \text{Where: } \tau_i = \text{Index limiting shear stress - Pa (lb/ft}^2\text{);}$$
$$A = \text{Surface area of sample - cm}^2 \text{ (ft}^2\text{)}$$

Note: The RPMs of the impeller will be measured using a procedure consistent with its drive mechanism. For pneumatic units, a record of air pressure may be recorded at each shear stress increment. For electrical drive mechanisms, a record of resistance may be recorded. All such recordings should be correlated to the shear stress as measured by the load cell assembly.

A1.9 Plot index limiting shear stress vs. impeller RPMs (or indicator unit: e.g psi) specific to the RECP tested and use this relationship to determine shear stress levels during subsequent testing of the same RECP material.

A2.0 Standard Soils

A2.1 General soil type to be used for testing shall be sand. The sand shall comply with the sand gradation given in ASTM D 6460. The target gradation curves for the sand is included in Figure 1. The sand layers shall be compacted to 90% of Standard Proctor density, at a soil moisture within ±3% of optimum moisture content per ASTM D-698.

A2.2 If the RECP is to be soil filled, the additional cover soil is placed and compacted after the RECP placement. Calibration should be performed on the soil filled RECP.

ECTC Test Protocol
Proposed ASTM Test Method
(including ASTM revisions as of March 2004)

A3.0 Preparation of Vegetated Soil Cores

A3.1 Soil Pots. Standard soil pots shall be used (see Sec. 6.1.4). Holes shall be drilled into the bottom of the pots to provide for moisture relief. A piece of filter fabric is placed in the bottom and then the pots are filled with compacted sand, as follows: Fill and compact the cores with soil to within a distance to the top of the pots equal to the thickness of the TRM to be tested. Unless otherwise requested, compact soil to 80% of Standard Proctor density, at a soil moisture within $\pm 2\%$ of optimum moisture content per ASTM D-698. Each test should be conducted on freshly prepared cores.. One extra pot should be prepared for the purposes of calibration.

A3.2 Seeding. Uniformly spread seed over the surface of the soil pots at the rate of 1 seed per cm^2 . Use Tall Fescue (Grande) having 90 pls. Using Tall Fescue this equals approximately 325 seeds per pot.

A3.3 RECP & Infill Soil Placement. Cut RECP specimens of sufficient size to cover the soil pots and extend beyond the edges of the transition cover plate in the shear apparatus. Place one specimen centered over each pot and temporarily secure in place to prevent lifting during the initial germination process. If desired, the RECP can be filled with soil and compacted. (Ignore this step when preparing “control” pots.) Compress both the seed and the top soil using a 50 lb circular weight having a nominal diameter equivalent to the pot inside diameter. Add sufficient water to bring the placed and compacted topsoil to approximately 100% saturation (stop as soon as free water is apparent on the surface).

A3.4 Germination Conditions. Place the pots in the controlled environmental chamber conditioned at 21 ± 2 °C. Pots should be positioned below “warm white” fluorescent lighting producing 900 ± 100 ft-candles at the soil/canopy surface (typ. 6-9 inches below bulbs). Typical warm white characteristics for a 48-in long lamp include: Light output = 3300 lumens; Color Temperature = 3000K; Color Rendering = 85., for 14 hours per day. The pots shall be watered daily during the initial germination period (at least the first 14 days) by applying sufficient water to return the pots to a moisture content equivalent to the field capacity of the compacted sand. After the initial germination period (21 days) at least 90% of the seeds must germinate for the test pots to be used. When sufficient germination has been obtained, subsequently waterings should be twice per week. Beginning on the 21st day, 130 ml of a fertilizer solution of 1 tablespoon of Miracle Gro[®] Water Soluble Lawn Food per gallon of water shall be applied every 14 days.

Note: Weighing of pots before and after watering is a sufficiently accurate way to assess the changes in soil moisture and the necessary additional moisture to return the soil to field capacity.

A3.5 Growth Period. Growth should be continued until the average plant height is at least 6 inches. This amount of growth may take as long as 6 months. Plant maturation will be enhanced by cutting the fastest growing plants back to permit light penetration to the smaller plants.

A3.6 Shear Testing. Once sufficient germination and growth has taken place in accordance with Sections A3.1 thru 3.5, testing should proceed as outlined in Section 8, except that the pots should not be immersed for 24 hours prior to testing.

A3.7 Calculations

A3.7.1 Remove, dry, and record the Final Dry Mass (DM_f) of soil for each of the three cores for the RECP and bare soil control sets at each shear stress level.

A3.7.2 Calculate the average depth of Soil Loss (mm) for each Core (SL_c) as follows:

$$SL_c = (DM_i - DM_f) / Cd$$

Where DM_i = Initial dry soil mass of core (g)
 DM_f = Final dry soil mass of core (g)
 Cd = Core linear density (g / mm)

ECTC Test Protocol
Proposed ASTM Test Method
(including ASTM revisions as of March 2004)

A3.7.3 Calculate the Mean Soil Loss (SL_{avg}) in mm for each set of three cores by averaging the SL_c values of all three cores.

A3.7.4 Plot SL_{avg} vs. shear stress (in Pa and (lbs/sf)) for each 30minute test. On the graph, note the point at which 13 mm (0.5 in) of soil loss did or would be expected to occur.

A3.7.5 Calculate the Shear Stress Ratio (SSR) for the test RECP as follows:

$$SSR = \frac{tp_{(0.5 \text{ in } SL_{avg})}}{tc_{(0.5 \text{ in } SL_{avg})}}$$

Where: $tp_{(0.5 \text{ in } SL_{avg})}$ = Shear stress on RECP-protected cores at 0.5 inch average soil loss
 $tc_{(0.5 \text{ in } SL_{avg})}$ = Shear Stress on bare soil control cores at 0.5 inch average soil loss